

ENG



SUSTAINABLE COLD SOLUTIONS

# Transcritical CO<sub>2</sub>ndensing units



We know the art of achieving  
*a perfect temperature*

**BEIJER REF**

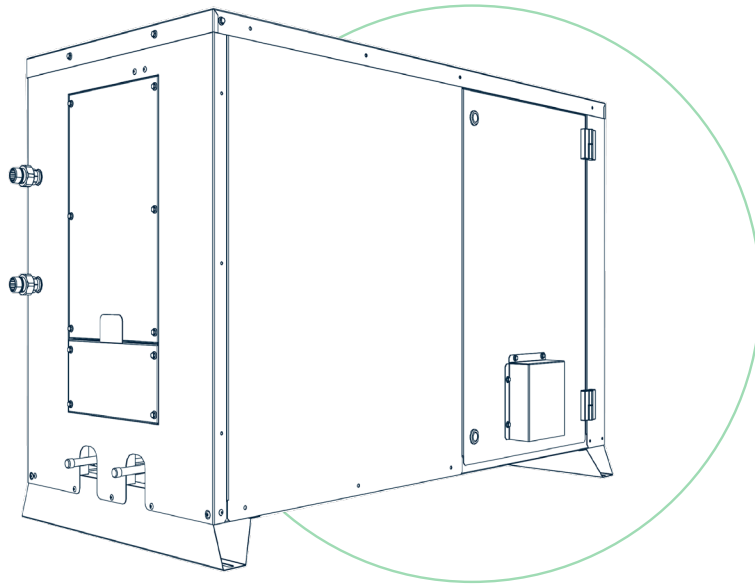

Condensing unit for transcritical CO<sub>2</sub> applications, equipped with a TOSHIBA BLDC compressor, water/brine brazed plate heat exchanger (BHE) gas cooler, and inverter. Its compact design ensures easy installation, and it can communicate directly with refrigeration units. These features guarantee high efficiency, even at part load.

**MAIN ADVANTAGES**

<p>CO<sub>2</sub> REFRIGERANT</p>	<p>EFFICIENT SOLUTION</p>	<p>SMALL FOOTPRINT</p>	<p>EASY START-UP</p>	<p>DC BRUSHLESS ROTARY COMPRESSOR</p>	<p>WATER COOLER EQUIPPED</p>	<p>PLUG &amp; PLAY HYDRAULIC CONNECTIONS</p>
-----------------------------------	---------------------------	------------------------	----------------------	---------------------------------------	------------------------------	--

## Cooling Capacity

### Transcritical Condensing Units DX

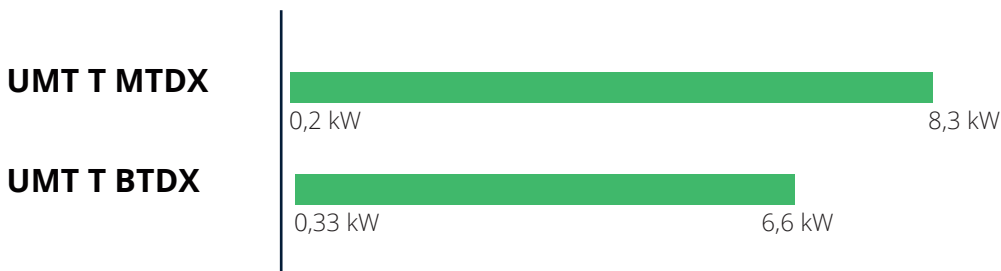

# Standard Accessories

- Toshiba BLDC compressors
- Carel controller
- Inverter modulation for capacity control 25 – 100%
- BHPE water/brine gas cooler
- Design pressure 130 bar (high pressure side) | 80 bar (liquid line) | 80 bar (suction line)
- Liquid receiver 12 liters
- K65 connections

# Accessories on Request

- Oil management (oil separator + reservoir, oil level control, oil return solenoid valve)
- Winter kit (suggested for ambient temperature < -20°C)

## Software Calculation Tool

Select your unit and check its CO2 charge

Configuration Selection Verify

Serie

Serie Cubo2ACQUA

Options

Compressor brand Toshiba BLDC



Input data

Selection

Required Capacity kW 5.00

Tolerance 10.00

Input

Evaporation temperature °C -10.00

Fluid temperature In °C 35.00

Fluid temperature Out °C 45.00

Fluid Water

There are no warnings

Model

Series Cubo2ACQUA

Unit UMTWGTN45BTDX

Min Load 0.97 kW

Max Load 2.66 kW

Compressor Model NY45D1F-10GU

Options

- Cofanatura standard
- Carel controller
- Gas cooler ad acqua
- Inverter with modulation 25-100%
- Design pressure 120/80/80
- Power supply 230V/1+N/50Hz
- Liquid receiver 8 liters (PED II)
- Ricevitore di liquido da 12 litri (PED II)

Working Point

Capacity 2.66 kW

Absorbed power 1.73 kW

COP 1.54

Flow Rate 39.49 kg/h

Current 16.10 A

Recommended protection -

Discharge Temperature 85.56 °C

Limits

Envelope

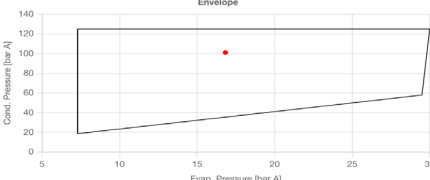

AT THE FOLLOWING LINK YOU CAN CHECK THE UNIT CHARGE.

<https://cubo2calculation.scmfrigo.com/#/home>



Ambient Temperature [°C]		Evaporation Temperature [°C]											
		-35		-30		-25		-20					
		Capacity [W]	COP	Capacity [W]	COP	Capacity [W]	COP	Capacity [W]	COP				
UMT WG T N045 BTDX		min	max	min	max	min	max	min	max				
	40	690	1191	1,18	830	2290	1,37	970	2660	1,54	1140	3100	1,76
	38	710	1930	1,23	860	2320	1,42	1000	2690	1,60	1180	3130	1,83
	32	770	2020	1,41	940	2410	1,64	1110	2780	1,86	1310	3222	2,13
	25	810	2080	1,57	990	2480	1,83	1170	2850	2,07	1390	3290	2,38
	15	910	2230	2,05	1110	2630	2,39	1310	3010	2,73	1560	3450	3,17
5	970	2290	2,32	1180	2700	2,75	1400	3080	3,17	1650	3520	3,73	
Water flow	720 L/h	MEPS <sup>(c)</sup>				2,29 (according to Ecodesign Directive EN 2009/125/EC)							
Weight	155 kg	Annual Energy Consumption				7846 kWh/year							
Pressure drop	15 kPa	Power Supply				230/1+N+PE/60							
Sound pressure <sup>(b)</sup>	38,8 dB(A)												

Ambient Temperature [°C]		Evaporation Temperature [°C]											
		-35		-30		-25		-20					
		Capacity [W]	COP	Capacity [W]	COP	Capacity [W]	COP	Capacity [W]	COP				
UMT WG N067 BTDX		min	max	min	max	min	max	min	max				
	40	1120	3050	1,27	1360	3640	1,45	1600	4180	1,62	1870	4800	1,80
	38	1140	3070	1,32	1380	3670	1,51	1620	4220	1,69	1890	4840	1,89
	32	1210	3160	1,51	1450	3780	1,75	1690	4360	1,96	1960	5000	2,21
	25	1250	3230	1,68	1500	3870	1,95	1740	4460	2,20	2010	5120	2,49
	15	1350	3400	2,19	1610	4060	2,57	1850	4680	2,93	2120	5370	3,37
5	1400	3470	2,50	1670	4150	2,97	1920	4780	3,44	2190	5490	4,02	
Water flow	1080 L/h	MEPS <sup>(c)</sup>				2,47 (according to Ecodesign Directive EN 2009/125/EC)							
Weight	155 kg	Annual Energy Consumption				11406 kWh/year							
Pressure drop	20 kPa	Power Supply				230/1+N+PE/60							
Sound pressure <sup>(b)</sup>	38,8 dB(A)												

Ambient Temperature [°C]		Evaporation Temperature [°C]											
		-35		-30		-25		-20					
		Capacity [W]	COP	Capacity [W]	COP	Capacity [W]	COP	Capacity [W]	COP				
UMT WG T 067 BTDX		min	max	min	max	min	max	min	max				
	40	950	4380	0,88	1190	5320	1,06	1360	6030	1,17	1660	7210	1,40
	38	950	4380	0,91	1190	5320	1,07	1360	6030	1,18	1660	7210	1,41
	32	950	4380	1,09	1190	5320	1,20	1360	6030	1,37	1660	7210	1,57
	25	950	4380	1,24	1190	5320	1,37	1360	6030	1,57	1660	7210	1,71
	15	950	4380	1,68	1190	5320	1,88	1360	6030	2,13	1660	7210	2,35
5	950	4380	2,04	1190	5320	2,32	1360	6030	2,59	1660	7210	2,68	
Water flow	1400 L/h	MEPS <sup>(c)</sup>				1,87 (according to Ecodesign Directive EN 2009/125/EC)							
Weight	195 kg	Annual Energy Consumption				21217 kWh/year							
Pressure drop	25 kPa	Power Supply				400/3+N+PE/60							
Sound pressure <sup>(b)</sup>	41,7 dB(A)												

Ambient Temperature [°C]		Evaporation Temperature [°C]											
		-35		-30		-25		-20					
		Capacity [W]	COP	Capacity [W]	COP	Capacity [W]	COP	Capacity [W]	COP				
UMT WG T 100 BTDX		min	max	min	max	min	max	min	max				
	40	1520	6540	0,89	1890	7900	1,08	2140	8940	1,17	2600	10650	1,40
	38	1520	6540	0,90	1890	7900	1,09	2140	8940	1,18	2600	10650	1,41
	32	1520	6540	1,18	1890	7900	1,27	2140	8940	1,43	2600	10650	1,58
	25	1520	6540	1,36	1890	7900	1,47	2140	8940	1,65	2600	10650	1,77
	15	1520	6540	1,91	1890	7900	2,08	2140	8940	2,33	2600	10650	2,51
5	1520	6540	2,35	1890	7900	2,66	2140	8940	2,92	2600	10650	2,93	
Water flow	1800 L/h	MEPS <sup>(c)</sup>				2,08 (according to Ecodesign Directive EN 2009/125/EC)							
Weight	195 kg	Annual Energy Consumption				28560 kWh/year							
Pressure drop	32 kPa	Power Supply				400/3+N+PE/60							
Sound pressure <sup>(b)</sup>	41,7 dB(A)												

### NOTES

<sup>(a)</sup> Inverter modulation from 25 - 100%, corresponding to 1500-6000 rpm

<sup>(b)</sup> Based on free field area weed semi-spherical sound emission in 10m distance; tolerance ± 2 dB(A)

<sup>(c)</sup> Minimum Energy Performance Standards, calculated according to Ecodesign Directive EN 2009/125/EC

# Technical data Cubo<sub>2</sub> Aqua (a)

MEDIUM TEMPERATURE

Ambient Temperature [°C]		Evaporation Temperature [°C]														
		-15		-10		-5		0		5						
		Capacity [W]	COP	Capacity [W]	COP	Capacity [W]	COP	Capacity [W]	COP	Capacity [W]	COP					
UMT WGT 030 MTDX	40	300	<b>1720</b>	1,24	390	<b>2080</b>	1,48	490	<b>2500</b>	1,75	600	<b>2960</b>	2,06	730	<b>3490</b>	2,42
	38	330	<b>1880</b>	1,35	420	<b>2280</b>	1,61	530	<b>2730</b>	1,92	660	<b>3240</b>	2,26	800	<b>3820</b>	2,65
	32	400	<b>2120</b>	1,74	510	<b>2560</b>	2,08	630	<b>3050</b>	2,48	770	<b>3620</b>	2,94	930	<b>4270</b>	3,47
	25	460	<b>2290</b>	2,11	570	<b>2740</b>	2,53	700	<b>3270</b>	3,02	850	<b>3870</b>	3,58	1030	<b>4560</b>	4,24
	15	620	<b>2860</b>	3,43	760	<b>3410</b>	4,13	920	<b>4050</b>	4,95	1110	<b>4790</b>	5,92	1330	<b>5630</b>	7,05
	5	770	<b>3390</b>	4,99	930	<b>4030</b>	6,01	1130	<b>4780</b>	7,22	1350	<b>5650</b>	8,66	-	-	-
	Water flow	720 L/h		MEPS <sup>(c)</sup>				3,80 (according to Ecodesign Directive EN 2009/125/EC)								
Weight	151 kg		Annual Energy Consumption				4141 kWh/year									
Pressure drop	15 kPa		Power Supply				230/1+N+PE/60									
Sound pressure <sup>(b)</sup>	37,3 dB(A)															
Ambient Temperature [°C]		Evaporation Temperature [°C]														
		-15		-10		-5		0		5						
		Capacity [W]	COP	Capacity [W]	COP	Capacity [W]	COP	Capacity [W]	COP	Capacity [W]	COP					
UMT WGT 045 MTDX	40	520	<b>2880</b>	1,19	650	<b>3430</b>	1,41	810	<b>4050</b>	1,65	980	<b>4740</b>	1,93	1190	<b>5520</b>	2,24
	38	560	<b>3150</b>	1,30	710	<b>3750</b>	1,54	880	<b>4430</b>	1,81	1080	<b>5190</b>	2,11	1300	<b>6050</b>	2,45
	32	680	<b>3490</b>	1,68	840	<b>4140</b>	1,98	1030	<b>4880</b>	2,33	1250	<b>5720</b>	2,74	1500	<b>6670</b>	3,20
	25	760	<b>3700</b>	2,03	940	<b>4380</b>	2,4	1140	<b>5160</b>	2,83	1370	<b>6060</b>	3,34	1640	<b>7070</b>	3,91
	15	1000	<b>4510</b>	3,30	1220	<b>5330</b>	3,92	1470	<b>6270</b>	4,66	1750	<b>7360</b>	5,52	2080	<b>8610</b>	6,53
	5	1220	<b>5260</b>	4,81	1470	<b>6220</b>	5,74	1770	<b>7330</b>	6,84	2100	<b>8610</b>	8,15	-	-	-
	Water flow	1080 L/h		MEPS <sup>(c)</sup>				3,63 (according to Ecodesign Directive EN 2009/125/EC)								
Weight	151 kg		Annual Energy Consumption				7007 kWh/year									
Pressure drop	20 kPa		Power Supply				230/1+N+PE/60									
Sound pressure <sup>(b)</sup>	37,3 dB(A)															
Ambient Temperature [°C]		Evaporation Temperature [°C]														
		-15		-10		-5		0		5						
		Capacity [W]	COP	Capacity [W]	COP	Capacity [W]	COP	Capacity [W]	COP	Capacity [W]	COP					
UMT WGT 067 MTDX	40	710	<b>3820</b>	1,08	900	<b>4640</b>	1,29	1130	<b>5550</b>	1,52	1380	<b>6590</b>	1,80	1680	<b>7760</b>	2,11
	38	770	<b>4180</b>	1,18	990	<b>5070</b>	1,41	1230	<b>6080</b>	1,67	1520	<b>7220</b>	1,97	1840	<b>8510</b>	2,31
	32	920	<b>4720</b>	1,52	1160	<b>5690</b>	1,81	1460	<b>6800</b>	2,16	1750	<b>8060</b>	2,56	2110	<b>9490</b>	3,02
	25	1030	<b>5090</b>	1,84	1280	<b>6110</b>	2,2	1570	<b>7280</b>	2,62	1910	<b>8620</b>	3,12	2300	<b>10140</b>	3,69
	15	1380	<b>6350</b>	2,99	1690	<b>7590</b>	3,59	2050	<b>9010</b>	4,31	2470	<b>10650</b>	5,15	2950	<b>12520</b>	6,14
	5	1710	<b>7530</b>	4,34	2080	<b>8970</b>	5,23	2500	<b>10640</b>	6,29	2850	<b>12020</b>	6,77	-	-	-
	Water flow	1440 L/h		MEPS <sup>(c)</sup>				3,30 (according to Ecodesign Directive EN 2009/125/EC)								
Weight	152 kg		Annual Energy Consumption				10585 kWh/year									
Pressure drop	25 kPa		Power Supply				230/1+N+PE/60									
Sound pressure <sup>(b)</sup>	40,2 dB(A)															
Ambient Temperature [°C]		Evaporation Temperature [°C]														
		-15		-10		-5		0		5						
		Capacity [W]	COP	Capacity [W]	COP	Capacity [W]	COP	Capacity [W]	COP	Capacity [W]	COP					
UMT WGT 100 MTDX	40	1170	<b>5840</b>	1,1	1470	<b>7030</b>	1,29	1820	<b>8360</b>	1,51	2220	<b>9870</b>	1,76	2660	<b>11560</b>	2,04
	38	1280	<b>6390</b>	1,2	1610	<b>7680</b>	1,41	1990	<b>9150</b>	1,65	2430	<b>10810</b>	1,93	2920	<b>12670</b>	2,23
	32	1510	<b>7170</b>	1,55	1880	<b>8580</b>	1,83	2300	<b>10180</b>	2,15	2780	<b>12010</b>	2,51	3340	<b>14080</b>	2,92
	25	1680	<b>7690</b>	1,89	2060	<b>9160</b>	2,23	2510	<b>10850</b>	2,62	3030	<b>12790</b>	3,07	3620	<b>14980</b>	3,59
	15	2200	<b>9480</b>	3,11	2680	<b>11260</b>	3,69	3230	<b>13310</b>	4,37	3870	<b>15680</b>	5,16	4600	<b>18380</b>	6,09
	5	2690	<b>11150</b>	4,6	3250	<b>13230</b>	5,48	3900	<b>15620</b>	6,52	4660	<b>18400</b>	7,75	-	-	-
	Water flow	1800 L/h		MEPS <sup>(c)</sup>				3,42 (according to Ecodesign Directive EN 2009/125/EC)								
Weight	152 kg		Annual Energy Consumption				15444 kWh/year									
Pressure drop	32 kPa		Power Supply				400/3+N+PE/60									
Sound pressure <sup>(b)</sup>	40,2 dB(A)															

## NOTES

<sup>(a)</sup> Inverter stage SST variable from -5 °C to 0°C according to operating conditions. Inverter modulation from 25 - 100%, corresponding to 1500-6000 rpm

<sup>(b)</sup> Based on free field area sound semi-spherical sound emission in 10m distance; tolerance ± 2 dB(A)

<sup>(c)</sup> Minimum Energy Performance Standards, calculated according to Ecodesign Directive EN 2009/125/EC

# Dimensional Data

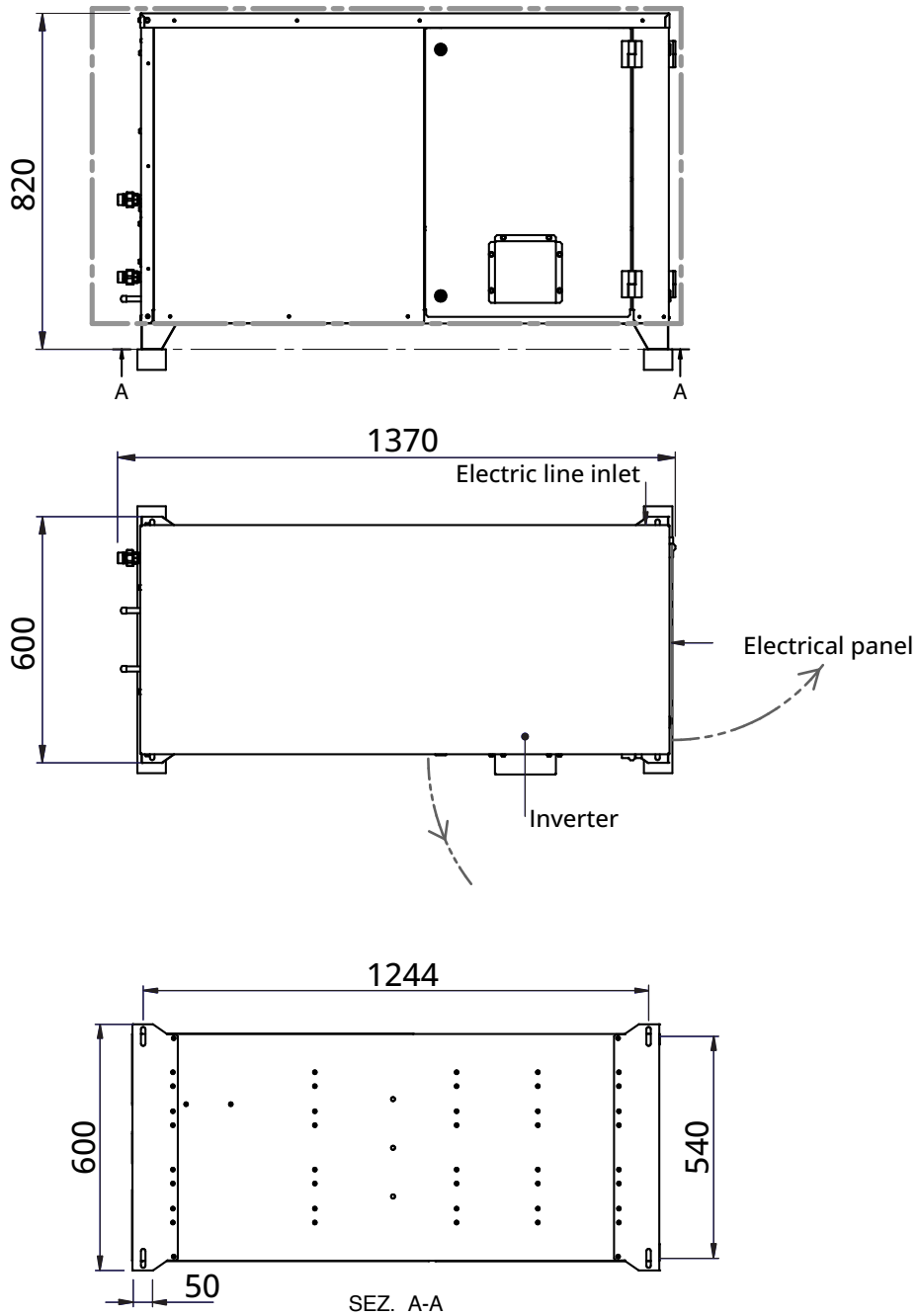





- SCM Frigo External sales, Branches & Partners
- SCM Ref OEM

**Discover our global network:**

[www.beijerref.com/operations/our-companies-and-branches](http://www.beijerref.com/operations/our-companies-and-branches)

## Stay connected.

Follow our LinkedIn page to discover more stories from our team and insights into what makes SCM Frigo a leader in innovation and sustainability.



Connect with Us  
on LinkedIn

[www.scmfrigo.com](http://www.scmfrigo.com) [+39 049 970 5000](tel:+390499705000) [info@scmfrigo.com](mailto:info@scmfrigo.com)



A **BEIJER REF** Company

SCM FRIGO S.p.A. - Viale Andrea Palladio, 31 35020 Sant'Angelo di Piove di Sacco

