

USA



SUSTAINABLE COLD SOLUTIONS

Transcritical CO₂ndensing units







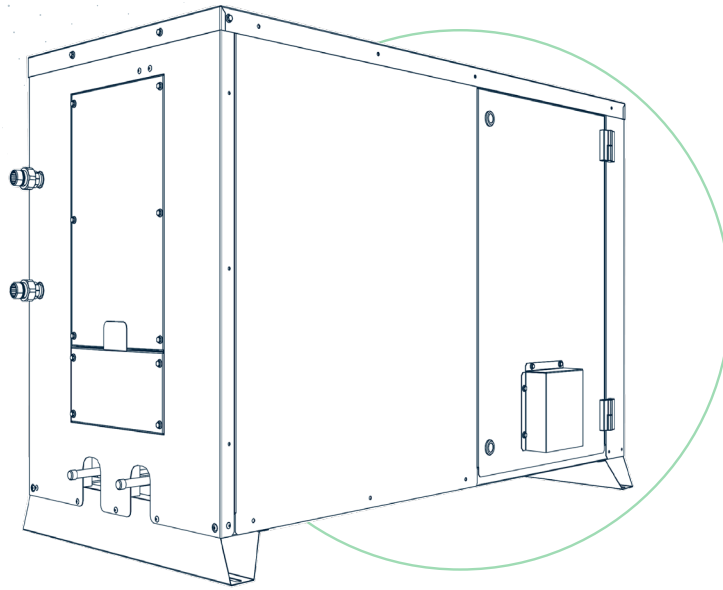

We know the art of achieving
a perfect temperature

BEIJER REF



Condensing unit for transcritical CO₂ applications, equipped with a TOSHIBA BLDC compressor, water/brine brazed plate heat exchanger (BHE) gas cooler, and inverter. Its compact design ensures easy installation, and it can communicate directly with refrigeration units. These features guarantee high efficiency, even at part load.

MAIN ADVANTAGES

 <p>CO₂ REFRIGERANT</p>	 <p>EFFICIENT SOLUTION</p>	 <p>SMALL FOOTPRINT</p>	 <p>EASY START-UP</p>	 <p>DC BRUSHLESS ROTARY COMPRESSOR</p>	 <p>WATER COOLER EQUIPPED</p>	 <p>PLUG & PLAY HYDRAULIC CONNECTIONS</p>
---	---	--	--	--	--	--

Cooling Capacity

Transcritical Condensing Units DX

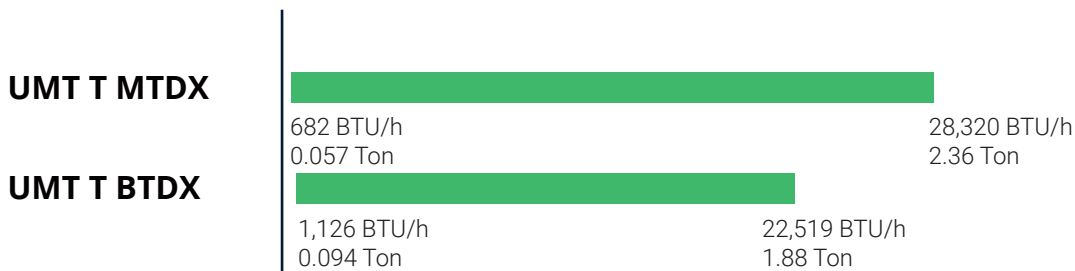

Standard Accessories

- Toshiba BLDC compressors
- Carel controller
- Inverter modulation for capacity control 25–100%
- BHPE water/brine gas cooler
- Design pressure 130 bar / 1885 PSI (high pressure side) | 80 bar/1160 PSI (liquid line) | 80 bar / 1160 PSI (suction line)
- ASME Liquid receiver 0.424 ft³
- UL Certified equipment
- K65 connections

Accessories on Request

- Oil management (oil separator + reservoir, oil level control, oil return solenoid valve)
- Winter kit (suggested for ambient temperature < -4 °F)

Software Calculation Tool

Select your unit and check its CO2 charge

Configuration Selection Verify

Serie:

Options:



Input data

Required Capacity: Btu/h

Tolerance:

Evaporation temperature: °F

Fluid temperature In: °F

Fluid temperature Out: °F

Fluid:

There are no warnings ✓

Model		Options	
Series	Cubo2ACQUA	<input checked="" type="checkbox"/> Standard enclosure	
Unit	UMTWGTN45BTDX	<input checked="" type="checkbox"/> Carel controller	
Min Load	3297.55 Btu/h	<input checked="" type="checkbox"/> Gas cooler ad acqua	
Max Load	9082.81 Btu/h	<input checked="" type="checkbox"/> Inverter with modulation 25-100%	
Compressor Model	NY45D1F-10GU	<input checked="" type="checkbox"/> Design pressure 120/80/80	
		<input checked="" type="checkbox"/> Power supply 230V/1+N/50Hz	
		<input type="checkbox"/> Liquid receiver 8 liters (PED II) - Phase out	
		<input checked="" type="checkbox"/> Liquid receiver 12 liters (PED II)	

Working Point	
Capacity	9082.81 Btu/h
Absorbed power	1.73 kW
COP	1.54
Flow Rate evaporator	87.08 lb/h
Current	16.10 A
Recommended protection	-
Discharge Temperature	186.00 °F

Limits

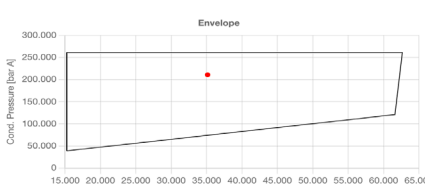

AT THE FOLLOWING LINK YOU CAN CHECK THE UNIT CHARGE.

<https://cubo2calculation.scmfrigo.com/#/home>



Technical data Cubo₂ Aqua (a)

LOW TEMPERATURE

Ambient Temperature [°F]		Evaporation Temperature [°F]											
		-31			-22			-13			-4		
		Capacity [kBTU/h]		COP	Capacity [kBTU/h]		COP	Capacity [kBTU/h]		COP	Capacity [kBTU/h]		COP
min	max	min	max		min	max		min	max				
UMT WG T N45 BTDX	104	2.354	4.064	1.18	2.832	7.814	1.37	3.310	9.076	1.54	3.890	10.578	1.76
	100.4	2.423	6.585	1.23	2.934	7.916	1.42	3.412	9.179	1.60	4.026	10.680	1.83
	89.6	2.627	6.893	1.41	3.207	8.223	1.64	3.787	9.486	1.86	4.470	10.994	2.13
	77	2.764	7.097	1.57	3.378	8.462	1.83	3.992	9.725	2.07	4.743	11.226	2.38
	59	3.105	7.609	2.05	3.787	8.974	2.39	4.470	10.271	2.73	5.323	11.772	3.17
	41	3.310	7.814	2.32	4.026	9.213	2.75	4.777	10.509	3.17	5.630	12.011	3.73
Water flow	3.2 gpm				Sound pressure ^(b)	38.8 dB(A)							
Pressure drop	2.18 psi				Power Supply	230/1+N+PE/60							
Weight	341.7 lbs												
Ambient Temperature [°F]		Evaporation Temperature [°F]											
		-31			-22			-13			-4		
		Capacity [kBTU/h]		COP	Capacity [kBTU/h]		COP	Capacity [kBTU/h]		COP	Capacity [kBTU/h]		COP
min	max	min	max		min	max		min	max				
UMT WG T N67 BTDX	104	3.822	10.407	1.27	4.641	12.420	1.45	5.459	14.263	1.62	6.381	16.378	1.80
	100.4	3.890	10.475	1.32	4.709	12.523	1.51	5.528	14.399	1.69	6.449	16.515	1.89
	89.6	4.129	10.782	1.51	4.948	12.898	1.75	5.767	14.877	1.96	6.688	17.061	2.21
	77	4.265	11.021	1.68	5.118	13.205	1.95	5.937	15.218	2.20	6.858	17.470	2.49
	59	4.606	11.601	2.19	5.494	13.853	2.57	6.312	15.969	2.93	7.234	18.323	3.37
	41	4.777	11.840	2.50	5.698	14.160	2.97	6.551	16.310	3.44	7.473	18.733	4.02
Water flow	4.8 gpm				Sound pressure ^(b)	38.8 dB(A)							
Pressure drop	2.90 psi				Power Supply	230/1+N+PE/60							
Weight	341.7 lbs												
Ambient Temperature [°F]		Evaporation Temperature [°F]											
		-31			-22			-13			-4		
		Capacity [kBTU/h]		COP	Capacity [kBTU/h]		COP	Capacity [kBTU/h]		COP	Capacity [kBTU/h]		COP
min	max	min	max		min	max		min	max				
UMT WG T 067 BTDX	104	3.242	14.945	0.88	4.060	18.153	1.06	4.641	20.575	1.17	5.664	24.602	1.40
	100.4	3.242	14.945	0.91	4.060	18.153	1.07	4.641	20.575	1.18	5.664	24.602	1.41
	89.6	3.242	14.945	1.09	4.060	18.153	1.20	4.641	20.575	1.37	5.664	24.602	1.57
	77	3.242	14.945	1.24	4.060	18.153	1.37	4.641	20.575	1.57	5.664	24.602	1.71
	59	3.242	14.945	1.68	4.060	18.153	1.88	4.641	20.575	2.13	5.664	24.602	2.35
	41	3.242	14.945	2.04	4.060	18.153	2.32	4.641	20.575	2.59	5.664	24.602	2.68
Water flow	6.2 gpm				Sound pressure ^(b)	41.7 dB(A)							
Pressure drop	3.63 psi				Power Supply	460/3+N+PE/60							
Weight	429.9 lbs												
Ambient Temperature [°F]		Evaporation Temperature [°F]											
		-31			-22			-13			-4		
		Capacity [kBTU/h]		COP	Capacity [kBTU/h]		COP	Capacity [kBTU/h]		COP	Capacity [kBTU/h]		COP
min	max	min	max		min	max		min	max				
UMT WG T 100 BTDX	104	5.186	22.315	0.89	6.449	26.956	1.08	7.302	30.505	1.17	8.872	36.339	1.40
	100.4	5.186	22.315	0.90	6.449	26.956	1.09	7.302	30.505	1.18	8.872	36.339	1.41
	89.6	5.186	22.315	1.18	6.449	26.956	1.27	7.302	30.505	1.43	8.872	36.339	1.58
	77	5.186	22.315	1.36	6.449	26.956	1.47	7.302	30.505	1.65	8.872	36.339	1.77
	59	5.186	22.315	1.91	6.449	26.956	2.08	7.302	30.505	2.33	8.872	36.339	2.51
	41	5.186	22.315	2.35	6.449	26.956	2.66	7.302	30.505	2.92	8.872	36.339	2.93
Water flow	7.9 gpm				Sound pressure ^(b)	41.7 dB(A)							
Pressure drop	4.64 psi				Power Supply	460/3+N+PE/60							
Weight	429.9 lbs												

NOTES

^(a) Inverter stage SST variable from 23 °F to 32 °F according to operating conditions. Inverter modulation from 25 - 100%, corresponding to 1500-6000 rpm

^(b) Based on free field area sound semi-spherical sound emission in 32.8 ft distance; tolerance ± 2 dB(A)

^(c) Minimum Energy Performance Standards, calculated according to Ecodesign Directive EN 2009/125/EC

Technical data Cubo₂ Aqua (a)

MEDIUM TEMPERATURE

		Evaporation Temperature [°F]														
UMT WG T 030 MTDX	Ambient Temperature [°F]	5			14			23			32			41		
		Capacity [kBTU/h]		COP	Capacity [kBTU/h]		COP	Capacity [kBTU/h]		COP	Capacity [kBTU/h]		COP	Capacity [kBTU/h]		COP
		min	max		min	max		min	max		min	max		min	max	
	104	1.024	5.869	1.24	1.331	7.097	1.48	1.672	8.530	1.75	2.047	10.100	2.06	2.491	11.908	2.42
	100.4	1.126	6.415	1.35	1.433	7.780	1.61	1.808	9.315	1.92	2.252	11.055	2.26	2.730	13.034	2.65
	89.6	1.365	7.234	1.74	1.740	8.735	2.08	2.150	10.407	2.48	2.627	12.352	2.94	3.173	14.570	3.47
	77	1.570	7.814	2.11	1.945	9.349	2.53	2.388	11.158	3.02	2.900	13.205	3.58	3.515	15.559	4.24
	59	2.116	9.759	3.43	2.593	11.635	4.13	3.139	13.819	4.95	3.787	16.344	5.92	4.538	19.210	7.05
	41	2.627	11.567	4.99	3.173	13.751	6.01	3.856	16.310	7.22	4.606	19.279	8.66	-	-	-
	Water flow	3.17 gpm			Sound pressure ^(b)			37.3 dB(A)								
	Pressure drop	2.18 psi			Power Supply			230/1+N+PE/60								
	Weight	332.9 lbs														

		Evaporation Temperature [°F]														
UMT WG T 045MTDX	Ambient Temperature [°F]	5			14			23			32			41		
		Capacity [kBTU/h]		COP	Capacity [kBTU/h]		COP	Capacity [kBTU/h]		COP	Capacity [kBTU/h]		COP	Capacity [kBTU/h]		COP
		min	max		min	max		min	max		min	max		min	max	
	104	1.774	9.827	1.19	2.218	11.704	1.41	2.764	13.819	1.65	3.344	16.174	1.93	4.060	18.835	2.24
	100.4	1.911	10.748	1.30	2.423	12.796	1.54	3.003	15.116	1.81	3.685	17.709	2.11	4.436	20.643	2.45
	89.6	2.320	11.908	1.68	2.866	14.126	1.98	3.515	16.651	2.33	4.265	19.517	2.74	5.118	22.759	3.20
	77	2.593	12.625	2.03	3.207	14.945	2.40	3.890	17.607	2.83	4.675	20.678	3.34	5.596	24.124	3.91
	59	3.412	15.389	3.30	4.163	18.187	3.92	5.016	21.394	4.66	5.971	25.113	5.52	7.097	29.379	6.53
	41	4.163	17.948	4.81	5.016	21.224	5.74	6.039	25.011	6.84	7.165	29.379	8.15	-	-	-
	Water flow	4.76 gpm			Sound pressure ^(b)			37.3 dB(A)								
	Pressure drop	2.90 psi			Power Supply			230/1+N+PE/60								
	Weight	332.9 lbs														

		Evaporation Temperature [°F]														
UMT WG T 067MTDX	Ambient Temperature [°F]	5			14			23			32			41		
		Capacity [kBTU/h]		COP	Capacity [kBTU/h]		COP	Capacity [kBTU/h]		COP	Capacity [kBTU/h]		COP	Capacity [kBTU/h]		COP
		min	max		min	max		min	max		min	max		min	max	
	104	2.423	13.034	1.08	3.071	15.832	1.29	3.856	18.937	1.52	4.709	22.486	1.80	5.732	26.478	2.11
	100.4	2.627	14.263	1.18	3.378	17.300	1.41	4.197	20.746	1.67	5.186	24.636	1.97	6.278	29.037	2.31
	89.6	3.139	16.105	1.52	3.958	19.415	1.81	4.982	23.203	2.16	5.971	27.502	2.56	7.200	32.381	3.02
	77	3.515	17.368	1.84	4.368	20.848	2.20	5.357	24.840	2.62	6.517	29.413	3.12	7.848	34.599	3.69
	59	4.709	21.667	2.99	5.767	25.898	3.59	6.995	30.743	4.31	8.428	36.339	5.15	10.066	42.720	6.14
	41	5.835	25.693	4.34	7.097	30.607	5.23	8.530	36.305	6.29	9.725	41.014	6.77	-	-	-
	Water flow	6.34 gpm			Sound pressure ^(b)			40.2 dB(A)								
	Pressure drop	3.63 psi			Power Supply			230/1+N+PE/60								
	Weight	335.1 lbs														

		Evaporation Temperature [°F]														
UMT WG T 100 MTDX	Ambient Temperature [°F]	5			14			23			32			41		
		Capacity [kBTU/h]		COP	Capacity [kBTU/h]		COP	Capacity [kBTU/h]		COP	Capacity [kBTU/h]		COP	Capacity [kBTU/h]		COP
		min	max		min	max		min	max		min	max		min	max	
	104	3.992	19.927	1.10	5.016	23.987	1.29	6.210	28.525	1.51	7.575	33.678	1.76	9.076	39.444	2.04
	100.4	4.368	21.804	1.20	5.494	26.205	1.41	6.790	31.221	1.65	8.292	36.885	1.93	9.963	43.232	2.23
	89.6	5.152	24.465	1.55	6.415	29.276	1.83	7.848	34.736	2.15	9.486	40.980	2.51	11.397	48.043	2.92
	77	5.732	26.239	1.89	7.029	31.255	2.23	8.564	37.022	2.62	10.339	43.641	3.07	12.352	51.114	3.59
	59	7.507	32.347	3.11	9.145	38.421	3.69	11.021	45.416	4.37	13.205	53.502	5.16	15.696	62.715	6.09
	41	9.179	38.045	4.60	11.089	45.143	5.48	13.307	53.298	6.52	15.901	62.783	7.75	-	-	-
	Water flow	7.93 gpm			Sound pressure ^(b)			40.2 dB(A)								
	Pressure drop	4.64 psi			Power Supply			460/3+N+PE/60								
	Weight	335.1 lbs														

NOTES

^(a) Insterstage SST variable from 23 °F to 32 °F according to operating conditions. Inverter modulation from 25 - 100%, corresponding to 1500-6000 rpm

^(b) Based on free field area weed semi-spherical sound emission in 32.8 ft distance; tolerance ± 2 dB(A)

^(c) Minimum Energy Performance Standards, calculated according to Ecodesign Directive EN 2009/125/EC

Dimensional Data

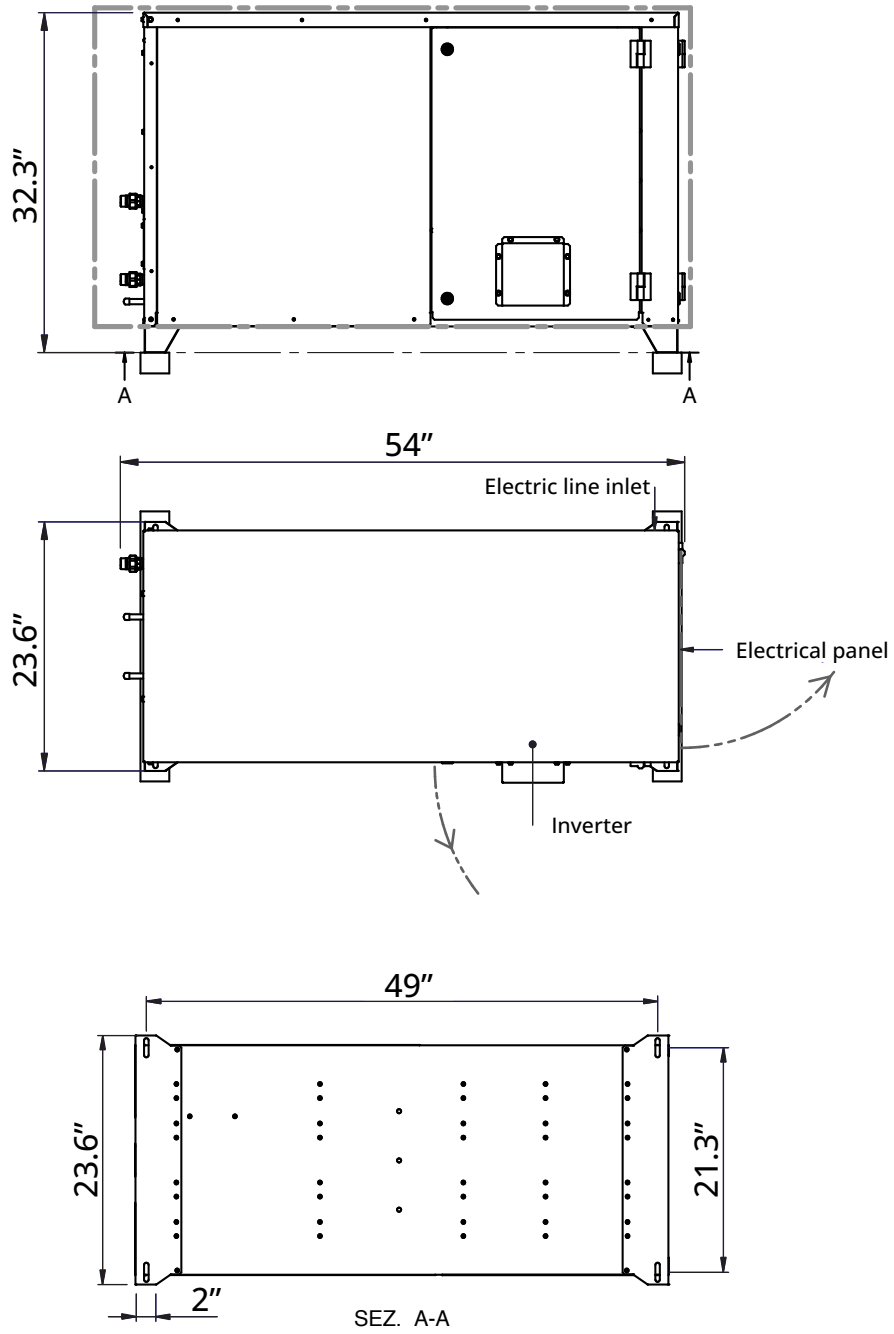



- SCM Frigo External sales, Branches & Partners
- SCM Ref OEM

Discover our global network:

www.beijerref.com/operations/our-companies-and-branches

Stay connected.

Follow our LinkedIn page to discover more stories from our team and insights into what makes SCM Frigo a leader in innovation and sustainability.



Connect with Us
on LinkedIn

- ☎ 1-855-789-COLD (2653) @ SCMUS@scmfrigo.com
- ☎ +39 049 970 5000 @ info@scmfrigo.com 🌐 www.scmfrigo.com



A **BEIJER REF** Company

SCM FRIGO S.p.A. - Viale Andrea Palladio, 31 35020 Sant'Angelo di Piove di Sacco

